

**RENAULT / OPEL / NISSAN****NUOVO MASTER 2.3 DCI / MOVANO 2.3 DCI EURO 6****NV400 2.3 DCI / INTERSTAR 2.3DCI (+/- AC) FWD EURO 6**

---

**CODE / CODICE: 0500.7942****COMPRESSOR / COMPRESSEUR / KOMPRESSOR  
/ COMPRESSORE / COMPRESOR :****SELTEC: TM13 / TM15****QUE: QP13 / QP15****SANDEN: SD5H14 / SD7H15**

---

**FITTING INSTRUCTIONS****EINBAUANLEITUNGEN****INSTRUCTIONS POUR LE MONTAGE****ISTRUZIONI DI MONTAGGIO****INSTRUCCIONES DE MONTAJE**



**Contents**

<b>ENGLISH</b> .....	4
Parts View.....	4
Parts List .....	5
Compatible Compressors .....	6
Standard Fastener Torque Values .....	6
Vehicle Details .....	7
Kit Details .....	7
Forward .....	7
Pre-Installation .....	8
Installation .....	8
Cover Modification.....	10
Mount Bracket Installation .....	13
Drive Belt .....	14
Belt Tension Table .....	15
Electrical Interface .....	16
Post Installation .....	16

PARTS VIEW / VUE ÉCLATÉE / TEILEANSICHT / VISTA PARTA / IMÁGENES DE LAS PIEZAS

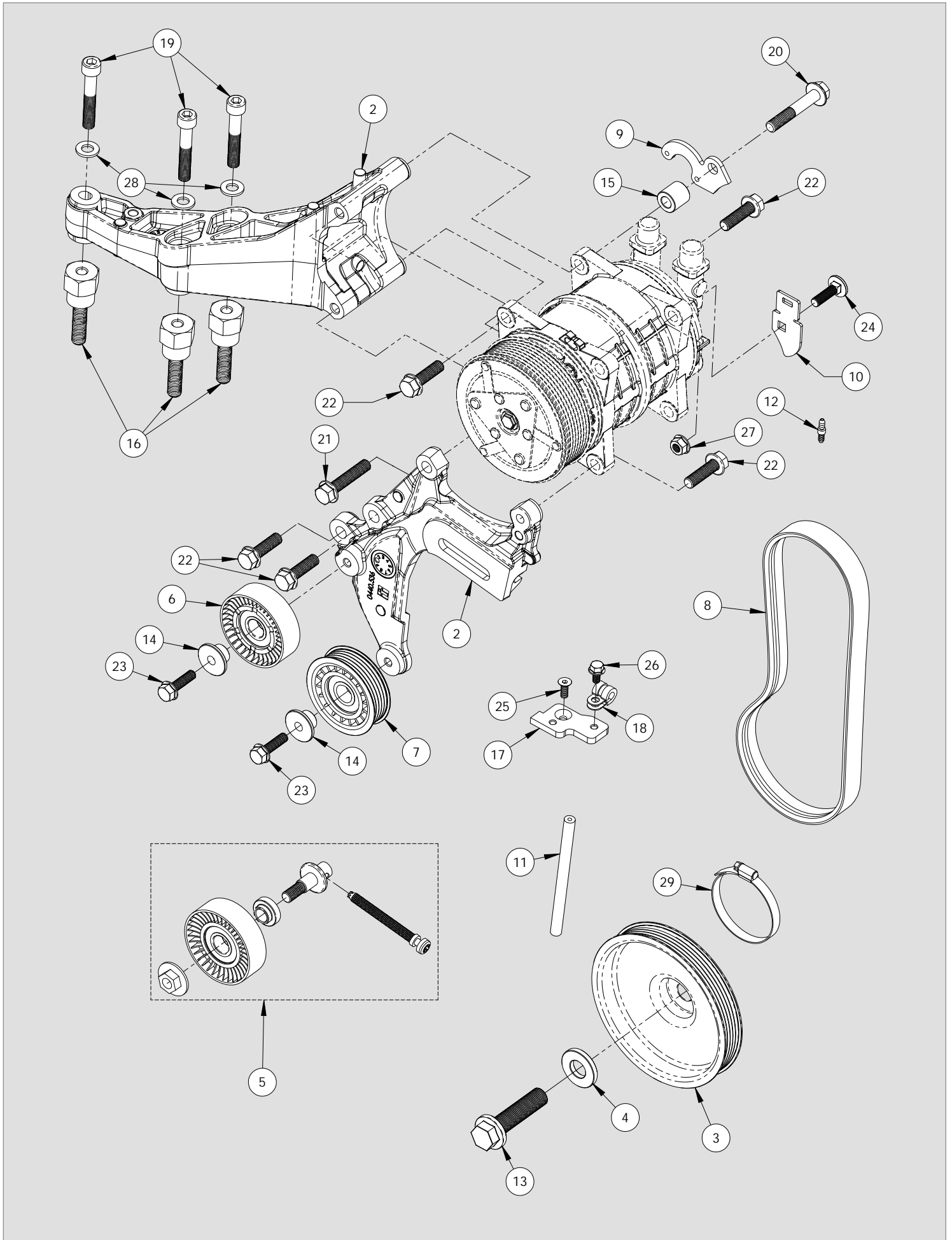

## PARTS LIST / NOMENCLATURE / TEILELISTE / ELENCO DELLE PARTI / LISTA DE PIEZAS

ITEM	CODE / CODICE / KODE / CODIGO	DESCRIPTION / DESCRIZIONE / BESCHREIBUNG / DESCRIPCION	QTY.	COMMENTS
1	0441.5351	CMB Assy - NV400 / Master / Movano 2.3 M9T FWD	1	
2	0440.5361	CMB - NV400 / Master / Movano 2.3 M9T FWD AC - B	1	
3	1701.5251	Crank Pulley - Renault 2.3 M9T FWD	1	
4	2803.5661	Crank Washer - M9T	1	
5	1705.5022	Belt Tensioner Assembly	1	
6	1700.5211	Back Idle Pulley 70x22 (5PK)	1	
7	1700.5221	5PK Idle Pulley	1	
8	0820.7011	Belt - Poly Groove 5PK 1500	1	
9	3020.6961	Fuel valve support bracket - M9T	1	
10	3020.6971	Jump start support bracket - M9T	1	
11	1420.0031	Fuel Hose - OD 9.5 X ID 3.5 X L130 mm	1	
12	1494.0031	Hose Connector (Ø4 hose)	1	
13	2711.0001	Hex Flange Screw M16x64:1.5 - 10.9	1	
14	2803.5611	Top hat spacer ID 8.3 OD 16.8 L14.5	2	
15	2803.6411	Spacer - 20.0 OD x 10.5 ID x 20L	1	
16	2803.5711	Threaded Pillar M12	3	
17	3020.5971	Hose Support Bracket	1	
18	2771.0541	P-Clip 10mm	1	
19	2705.5051	Hexagon socket head cap screw M10 x 60 : 1.50 - 12.9	3	
20	2705.5431	Hexagon flange Bolt M10 x 60 : 1.50 - 10.9	1	
21	2705.0341	Hexagon flange bolt Durlok - M10 x 50 : 1.50 - 12.9	1	
22	2705.0241	Hexagon flange bolt Durlok - M10 x 35 : 1.50 - 12.9	5	
23	2704.0091	Hexagon flange bolt Durlok - M8 x 30 : 1.25 - 12.9	2	
24	2704.5771	Coach Bolt M8 x 25 - DIN 603	1	
25	2702.5001	Flat Countersunk Head Cap Screw M6 x 16 : 1.00	1	
26	2702.0141	Hexagon flange bolt Durlok - M6 x 12 : 1.00 - 12.9	1	
27	2734.0021	Hexagon flange nut Durlok - M8 : 1.25	1	
28	2809.0011	Washer M10 Flat DIN 125 - A 10.5	3	
29	1537.1081	Hose Clamp 40-60	1	

**COMPATIBLE COMPRESSORS / COMPRESSEURS RECOMMANDÉS / EMPFOHLENE KOMPRESSOREN  
RACCOMANDATO COMPRESSORI / RECOMENDADAS COMPRESORES**

SELTEC	TM-13 HS	TM15-HS	-
Comp No	0381.0202	0381.0002	-
Valeo No.	488-45120	488-55120	-
Mounting	EAR	EAR	-
Rotor	8PV	8PV	-
GL	46.55mm	46.55mm	-
Armature	3E	3E	-
Diameter	123	123	-
Voltage	12	12	-
Orientation	V	V	-
Fitting	3/4 x 7/8	3/4 x 7/8	-
Manifold	Bolt	Bolt	-

QUE	QP13-HD	QP15-HD	-
Comp No	0391.0202	0391.0002	-
Que No.	QP13-1302	QP15-1171	-
Mounting	EAR	EAR	-
Rotor	8PV	8PV	-
GL	46.55mm	46.55mm	-
Armature	3E	3E	-
Diameter	123	123	-
Voltage	12	12	-
Orientation	V	V	-
Fitting	3/4 x 7/8	3/4 x 7/8	-
Manifold	Bolt	Bolt	-

SANDEN	-	SD5H14	SD7H15
Comp No.	-	0370.0051	0370.0061
Sanden No.	-	6629	8103
Mounting	-	EAR	EAR
Rotor	-	7PV	8PV
GL	-	46.55mm	46.55mm
Armature	-	SL	SL
Diameter	-	119	119
Voltage	-	12	12
Orientation	-	V	V
Fitting	-	3/4 x 7/8	3/4 x 7/8

DELPHI	-	SP15	-
Comp No	-	0310.0021	-
Delphi No.	-	015203/1	-
Mounting	-	EAR	-
Rotor	-	8PV	-
GL	-	50.1mm	-
Armature	-	SL	-
Diameter	-	122.4	-
Voltage	-	12	-
Orientation	-	V	-
Fitting	-	1-14 UNF-2A	-

**STANDARD FASTENER TORQUE VALUES**

In the absence of specific torque values detailed in this fitting instruction manual, the following chart can be used as a guide to the maximum safe torque for specific size and grade of fastener.

**COUPLES DE SERRAGE DES FIXATIONS STANDARDS**

Si des chiffres de serrage au couple particuliers ne sont pas indiqués dans cette notice de montage, se référer au tableau suivant qui servira de guide pour le couple de sécurité maximum correspondant à une taille et un grade spécifiques de fixation.

**ANZIEHMOMENTE FÜR STANDARDBEFESTIGUNGSMITTEL**





Falls in dieser Einbauanleitung keine speziellen Anziehmomente angegeben sind, kann die folgende Tabelle als Richtlinie für das maximale sichere Anziehmoment für eine spezifische Größe oder Qualität von Befestigungsmitteln dienen.

**VALORI STANDARD DI SERRAGGIO PER DISPOSITIVI DI FISSAGGIO**

In assenza di valori specifici di coppia nel presente manuale di istruzioni, si può utilizzare la seguente tabella come guida per conoscere la coppia massima sicura in base a dimensioni e grado del dispositivo di fissaggio.

**VALORES ESTÁNDAR DE LOS PARES DE APRIETE Y FIJACIÓN**

En ausencia de valores para los pares de apriete específicos detallados en este manual de instrucciones de montaje, se puede utilizar la siguiente tabla como guía para consultar el máximo par de torsión seguro para un tamaño concreto y su grado de fijación.

STRENGTH								
	Max Torque		Max Torque		Max Torque		Max Torque	
Dia / Pitch	lb.ft	Nm	lb.ft	Nm	lb.ft	Nm	lb.ft	Nm
M5 x 0.80	2	3	4.5	6	6.5	9	7.5	10
M6 x 1.00	4	5.5	7.5	10	11	15	13	18
M8 x 1.25	10	13	18	25	26	35	33	45
M10 x 1.25	20	27	39	53	57	78	66	90
M10 x 1.50	18	25	37	50	55	73	63	86
M12 x 1.75	33	45	63	85	97	130	111	150
M14 x 2.00	55	75	103	140	151	205	177	240
M16 x 2.00	85	115	159	215	232	315	273	370

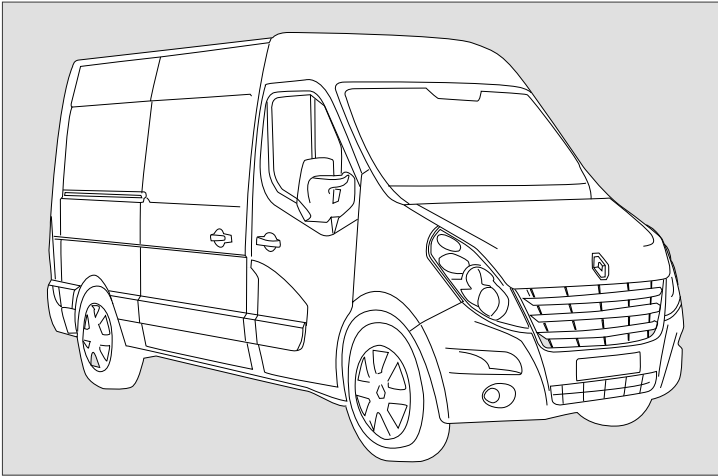

## VEHICLE DETAILS

Manufacturer	Vauxhall / Opel, Renault , Nissan
Make	Movano, Master, NV400
Model	FWD 2.3 CDTI / dCi
Engine CC	2299
Engine Details	Euro 6, M9T 110/130/145/165/170
Year	2016>
Chassis Nos.	N/A
LHD	YES
RHD	YES
PAS	YES
A/C	YES
Voltage	12v

## KIT DETAILS

Kit Part Number	0500.7942
Description	Standard Kit
Compressor RPM	4200 @ Max engine power output
Fitting Time	120 Minutes
Suction Fitting	90°
Discharge Fitting	90°
Belt Type	5PK 1500
Belt Part Number	0820.7011

Note: Fits vehicles with or without PTO.

Not compatible with Tecshift / Quickshift / Automatic / Robotised Gearbox Stop Start options. Vehicles with STOP/START options require the battery interface option CABADP/KPD

## FOREWORD

The purpose of this manual is to facilitate the installation of a direct drive compressor. The information given is merely instructive, should any complications arise contact the Technical department. The manufacturer's warranty does not cover any problems caused by defective installation or alterations made unless authorised. The manufacturer shall not be responsible for any injury, damage or loss caused directly or indirectly as a result of using this manual or the information contained within it.

### 1 SAFETY MEASURES:

**Before fitting the Compressor adapter drive kit, ensure the following for damage:**

- a Inner and outer trim and body work
- b Engine idle pace
- c Check all the vehicle functions

#### Check list:

- a Ensure that the right kit has been selected
- b Before installing, check that all the correct pieces are present; also ensure that there are no missing or broken pieces
- c When fitting, make sure the vehicle is properly protected against damage.

### Installation apparatus

- a Calibrated torque wrench
- b Hand service tools
- c Protective covers and shields

### 2 PRECAUTIONS

- a Detach the battery negative lead.
- b Torque all bolts where stated using a calibrated torque wrench.
- c Take extreme care with moving parts.
- d Remove the vehicle's ignition key and keep it with you.
- e Wear safeguards and make sure that liquid refrigerant never touches your skin

**Caution:** Measures must be followed accurately to steer clear of the possibility of damage to individuals

**Warning:** This calls awareness to actions which must be pursued to avoid damage to the components.

**NB:** This calls awareness to make the job easier or gives useful information.

**PRE-INSTALLATION**

**N.B** Prior to commencing work, please examine the instructions with care. The alphabetical symbols on the diagram relate to written instructions, numerical symbols relate to the parts listing.

**INSTALLATION**

1. Remove and retain the engine under panel and fasteners.
2. Turn the Automatic belt tensioner (A) fully clockwise. Insert a 3mm locking pin to hold in the fully open position. Remove and retain the original drive belt (B) – Fig 1

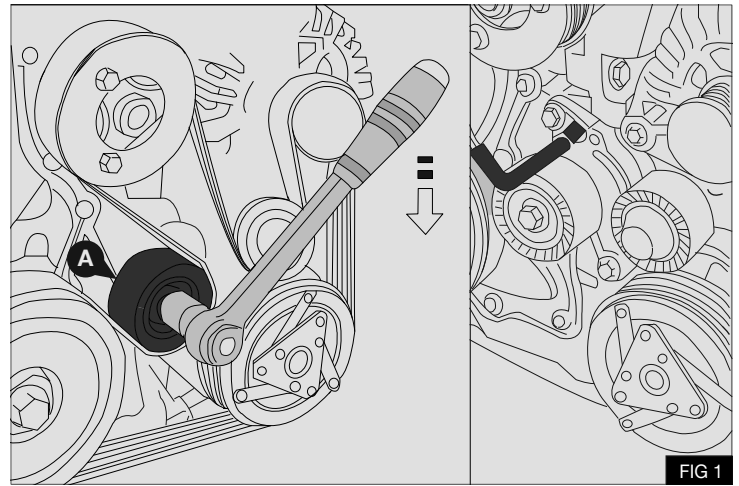

FIG 1

3. Remove and retain the M6 bolt (C) and flywheel protection plate (D) located at the rear of the engine behind the driveshaft – Fig 2

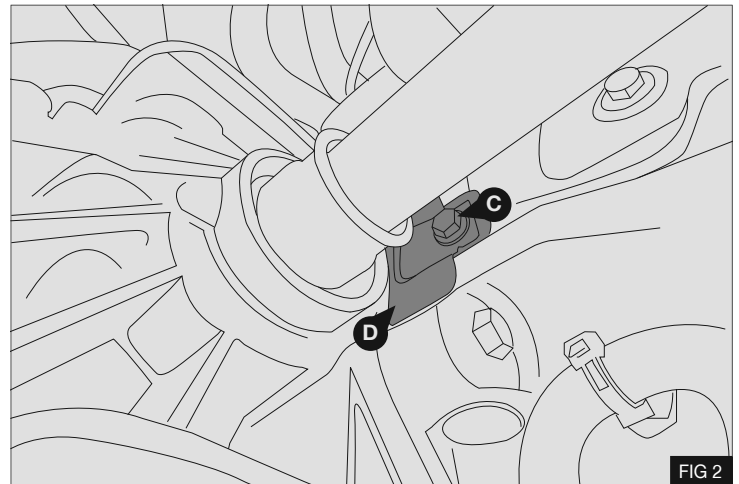

FIG 2

4. Lock the engine flywheel (E) using a large flat screwdriver – Fig 3

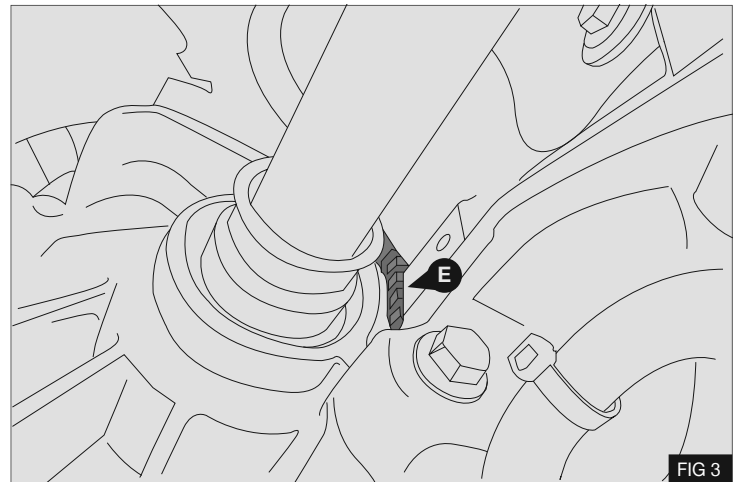

FIG 3

5. Remove the crank bolt (F). Discard crank bolt (F) and pulley spacer (G) – Fig 4

**N.B** If the Vehicle is equipped with a PTO pulley, remove and discard it.

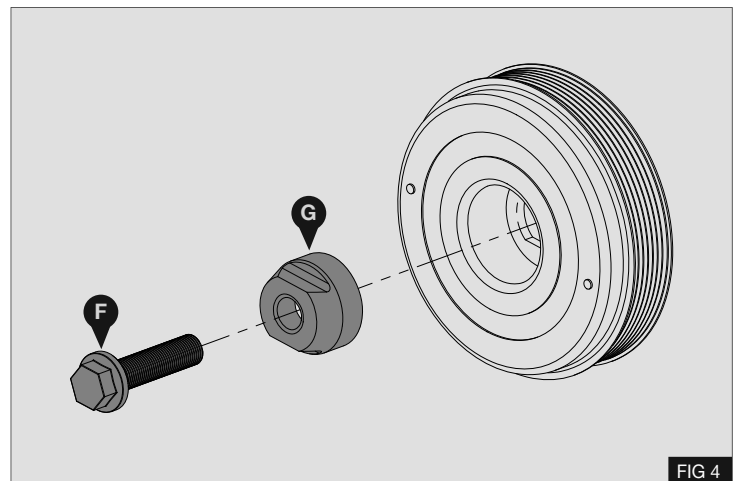
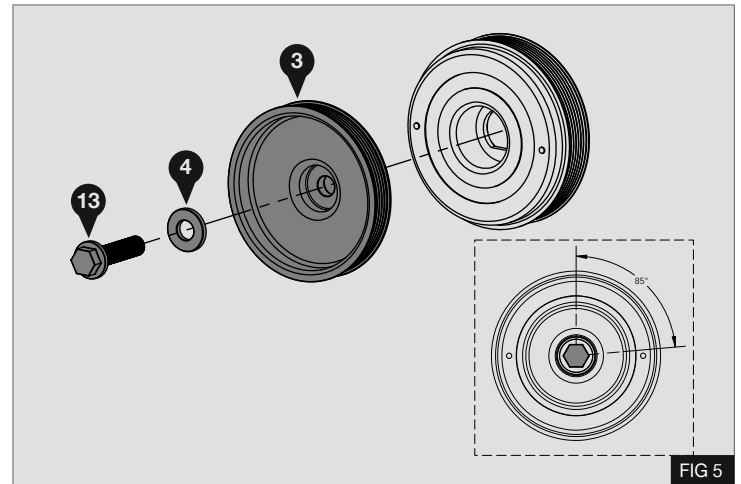

FIG 4



6. Fit the supplied pulley (3) with crank washer (4) and supplied bolt (13). Torque bolt (13) to 50Nm plus an angular tightening of 85 +/- 6 degrees - Fig 5
7. Replace the flywheel protection plate (D).

**CAUTION!:** FAILURE TO FOLLOW THE TIGHTENING PROCEDURE ABOVE RISKS CAUSING SERIOUS ENGINE DAMAGE. **DO NOT** USE AN AIR GUN TO TIGHTEN THE BOLT



8. Refit the original drive belt (B) - Fig 6

A – Crank Pulley  
 B – Tensioner Pulley  
 C – Water Pump  
 D – Idle Pulley  
 E – Alternator  
 F – AC compressor / Foolish Pulley

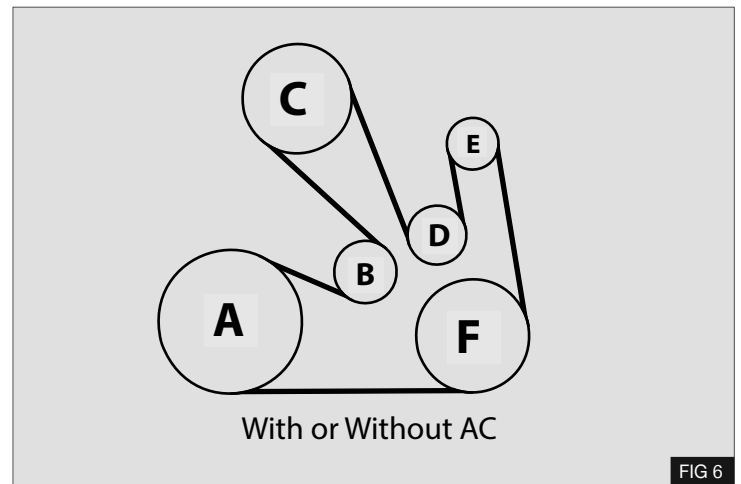

9. Remove the air intake hose (H), disconnect the wiring (J) to the air filter. Loosen the 4x screws (K) and remove the top half of the air filter. Remove the remaining lower section of the air filter - Fig 7

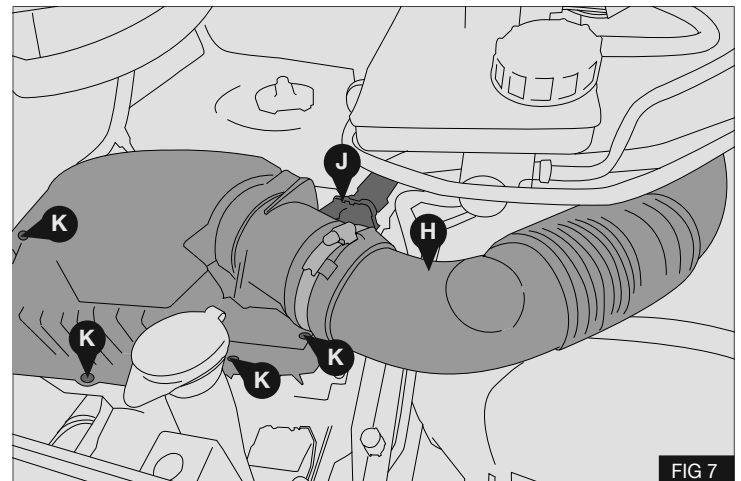

#### ALL VEHICLES

1. Remove the bolt (L) securing the AC pipe bracket (M) to the engine mount - Fig 8

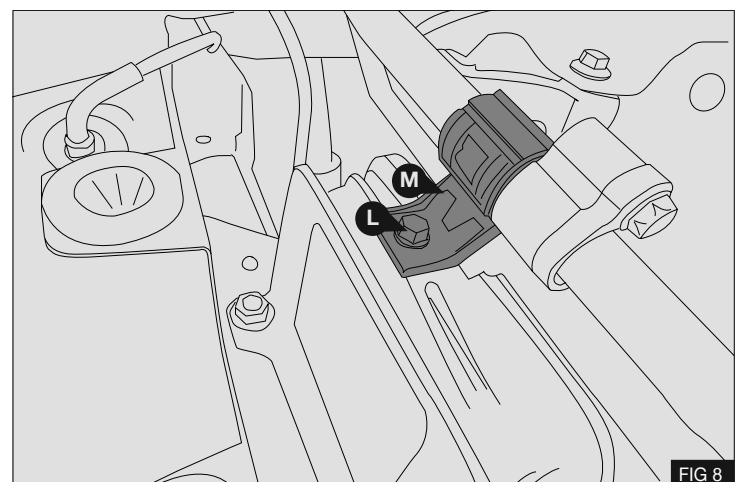

2. Install the supplied hose support bracket (17) to the engine mount bracket using countersunk bolt (25) - Fig 9

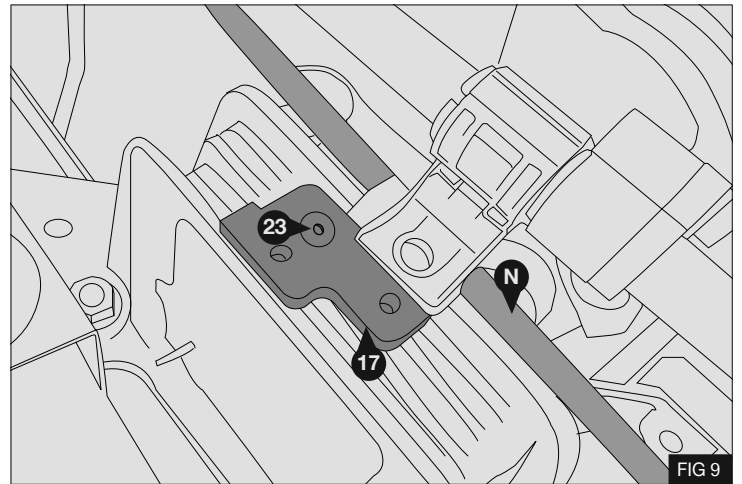

3. Fit the supplied pipe clip (18) to the AC hose (N) and secure to the support bracket (17) using bolt (26) - Fig 10

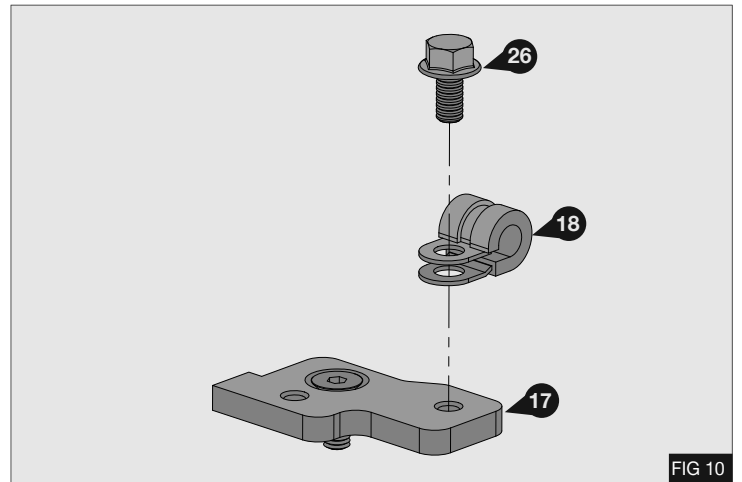

4. Secure the original AC pipe bracket (M) to the support bracket (17) using original bolt (L) - Fig 11

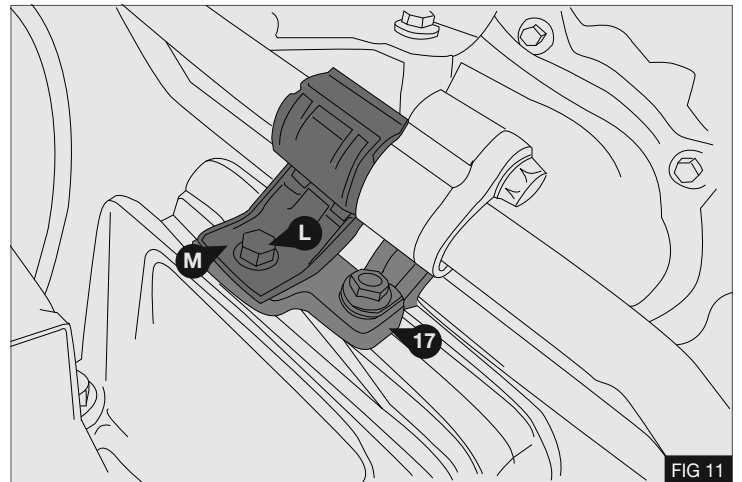

### COVER MODIFICATION

1. Undo bolts (O) and (P). Remove and discard bracket (Q) together with bolt (O) - Fig 12

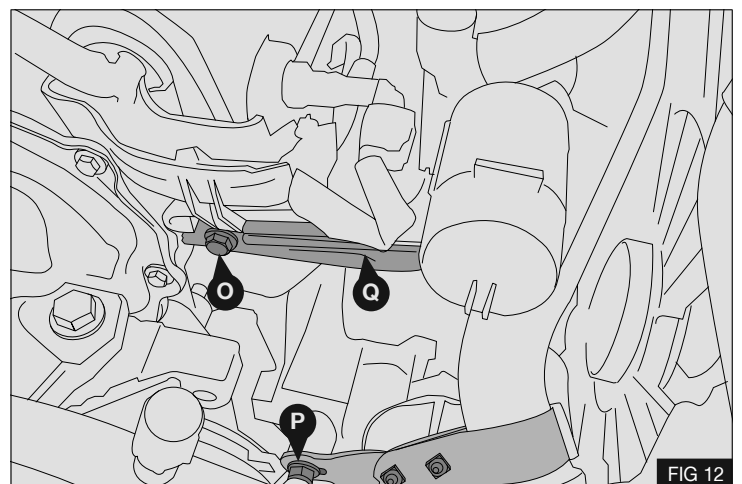

2. Mark the top intercooler pipe bracket **(R)** position, undo and discard intercooler silicone hose clamp **(S)** and remove 2 bolts **(T)** clamping the intercooler pipe. - Fig 13

**Note:** Pliers can be used to undo the hose clamp(s)

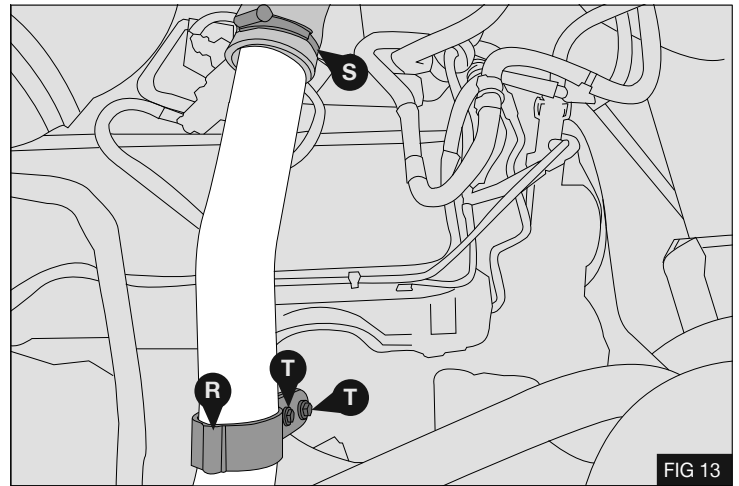

FIG 13

3. Remove clips holding the wiring and hoses **(U)** to the injector cover **(V)**. Undo 2 nuts **(W)** holding the Solenoid Valve and remove the lower vacuum hose **(X)** - Fig 14

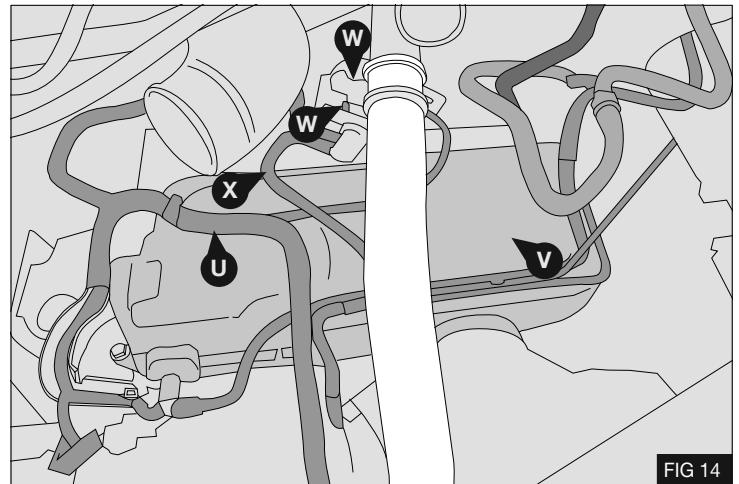

FIG 14

4. Undo 3 bolts **(Y)** holding injector cover. Undo and discard bolt **(Z)** holding the wiring loom support **(AA)**. Lift 2 clips **(AB)** and remove the cover.

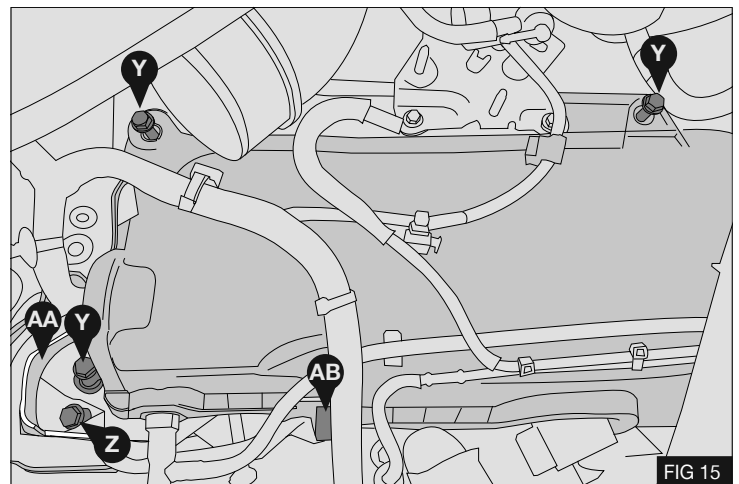

FIG 15

5. Disconnect the wiring connectors **(AC)** and **(AD)** and lift the wiring out of the holder **(AA)**.
6. Cut off and discard the plastic holder **(AA)** at the line marked. - Fig 16

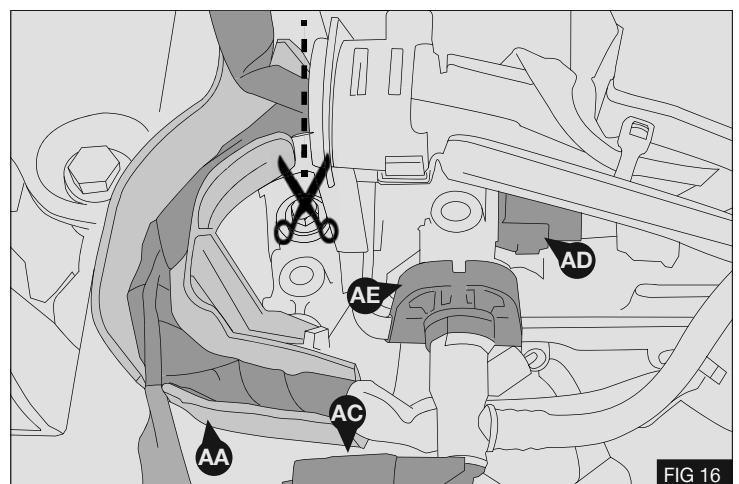
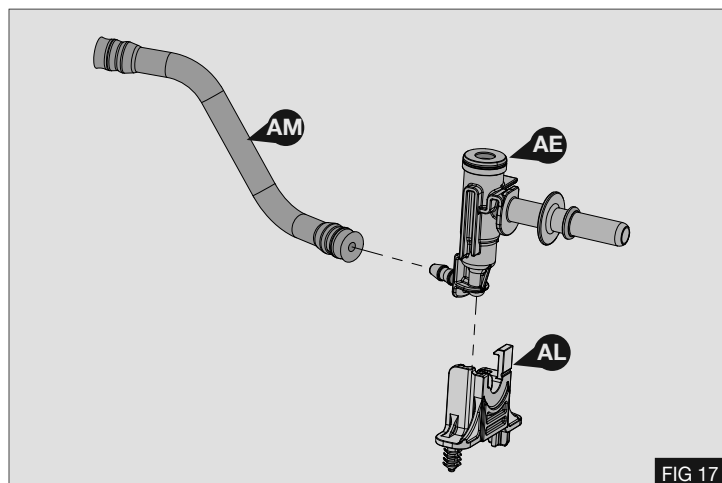
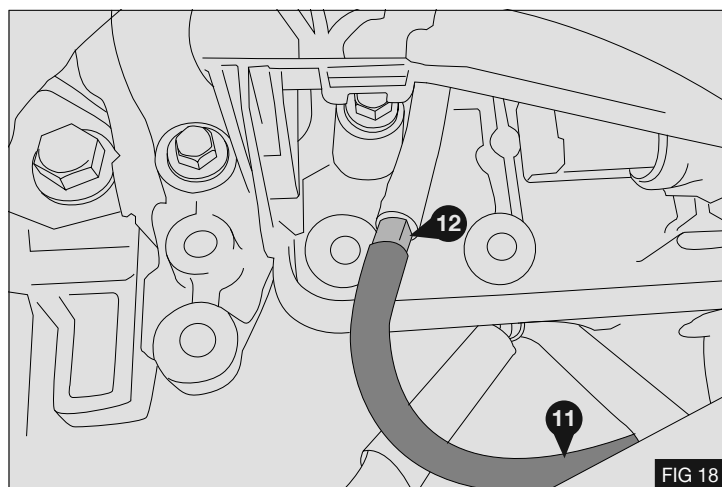

FIG 16

7. Remove the fuel return valve and bracket (AE) - Fig 16).



8. Extend the original fuel hose using hose connector (12) and fuel hose (11).



9. Refit the return valve (AE) using the original grommet while keeping the plastic bracket separate. - Fig 18

10. Reconnect connectors (AC) and (AD) (Fig 16), reassemble the injector cover (V) - Fig 16), and intercooler piping (Fig 15) in reverse order.

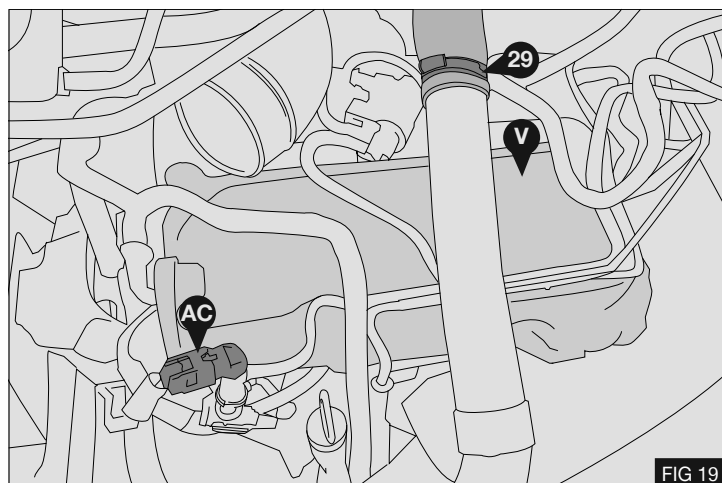

11. Use the supplied hose clamp (29) to reconnect the hose to the pipe. - Fig 19

### ALL VEHICLES

1. Remove and replace the engine mount bolts (AF) **one at a time** and replace with threaded pillars (16).

Torque the 3x threaded pillars (16) to 65 Nm / 48Lb. ft.  
- Fig 20a / b

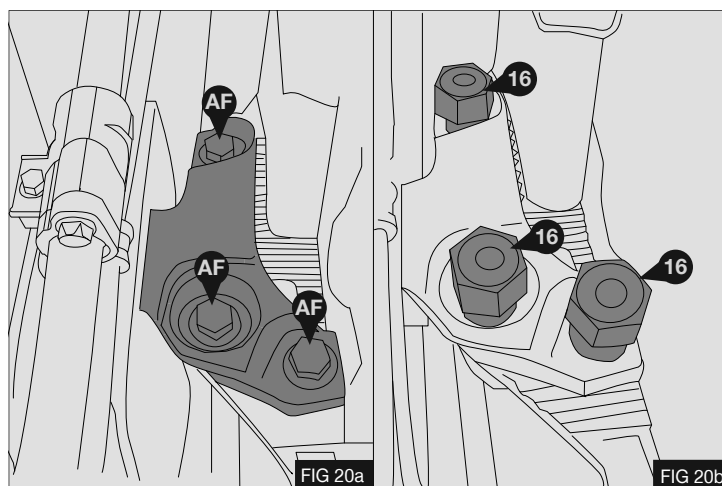

- Assemble the tensioner assembly as shown opposite using bracket (2) and tensioner assembly (5) - Fig 21

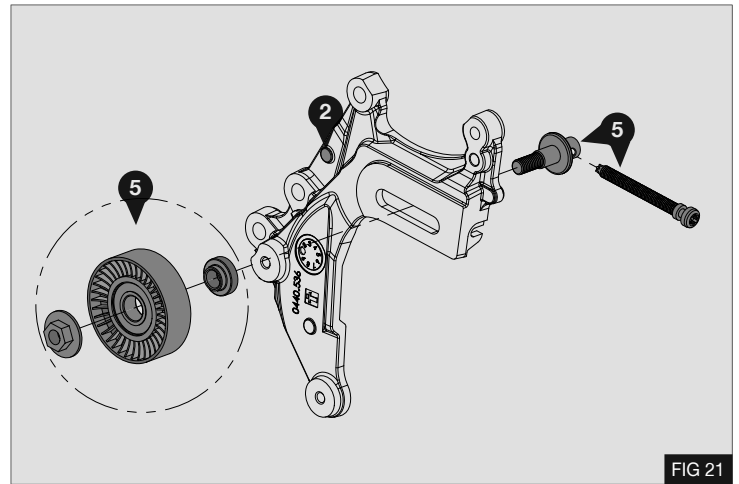

## MOUNT BRACKET INSTALLATION

**IMPORTANT:** The following installation and tightening sequence must be carefully followed to ensure correct belt and bracket alignment.

**NB:** Please refrain from using “Loctite” unless otherwise notified

- Install the mount bracket (1) to the threaded pillars (16) using bolts (19) with washers (28). Tighten the 3x bolts hand tight so that they only allow **side to side** movement of the bracket (1) - Fig 22
- Install the adjuster bracket (2) to the side of the engine using 2x M10x35 bolts (22). Tighten the 2x bolts hand tight so that they only allow **up and down** movement of the bracket - Fig 23
- Before fitting the compressor undo bolt (AG) and remove the suction/discharge manifold (AH) - Fig 24

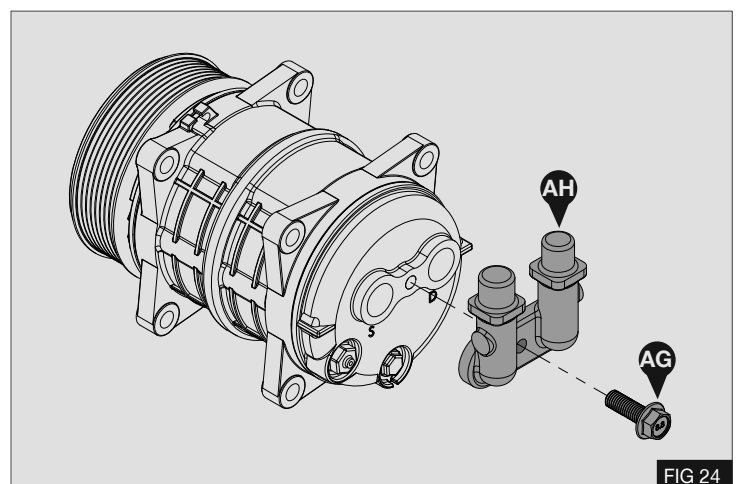
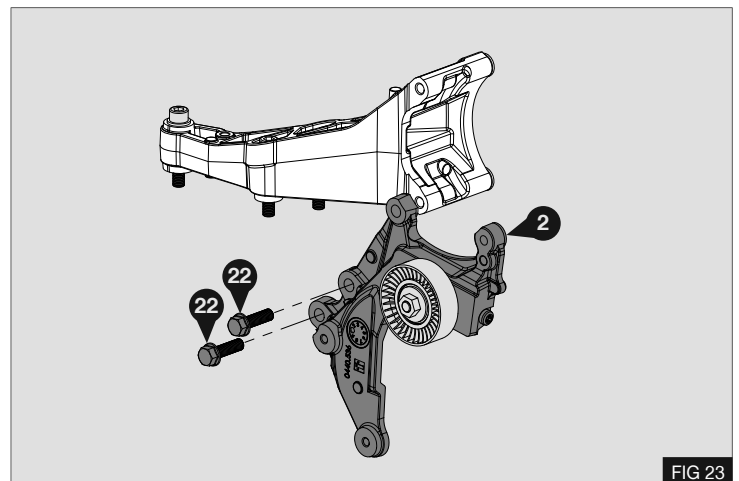
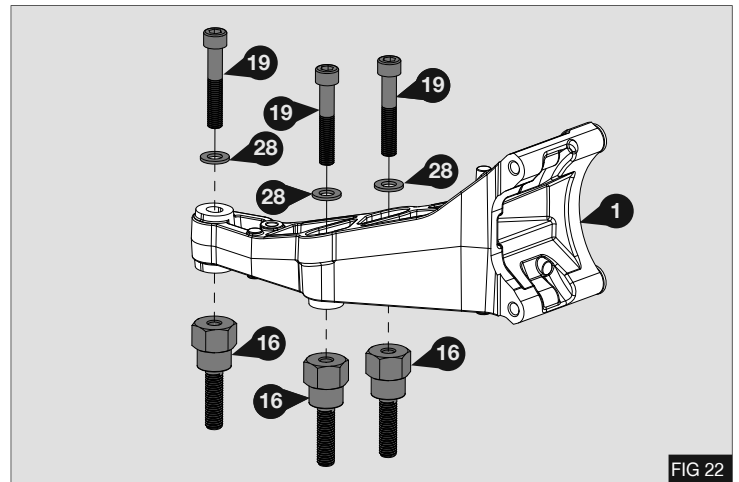

4. Secure the compressor using 2x M10x35 (22) bolts and 1x bolt M10x60 (20).
5. Attach fuel valve holder (AL) to bracket (9) and use spacer (15).
6. Attach the fuel return valve to its holder and Torque 3x M10 bolts to 58 Nm / 43lb. ft. in the following sequence: - Fig 25

**Bolt tightening sequence :**

- 1 - (22) A
- 2 - (20) B
- 3 - (22) C

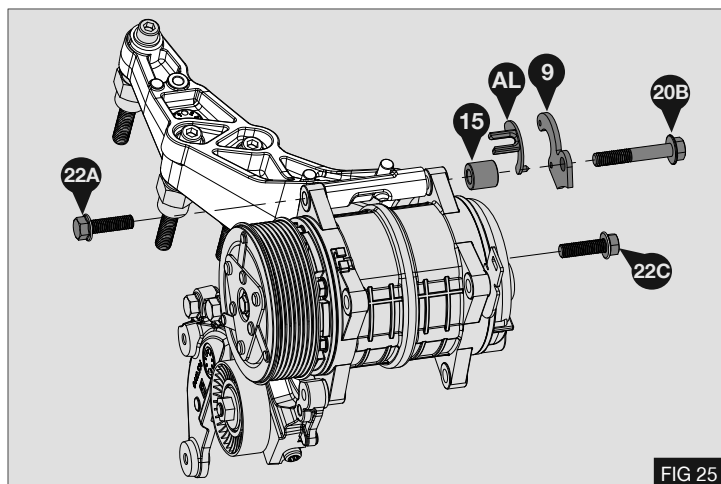

FIG 25

7. Insert M10x50 bolt (21) and M10x35 bolt (22) through the lower front compressor ears as shown opposite. Torque bolts (21) and (22) to 58Nm / 43lb. ft. - Fig 26
8. Torque bolts (22a) securing the adjuster bracket to 58Nm / 43lb. ft. - Fig 26

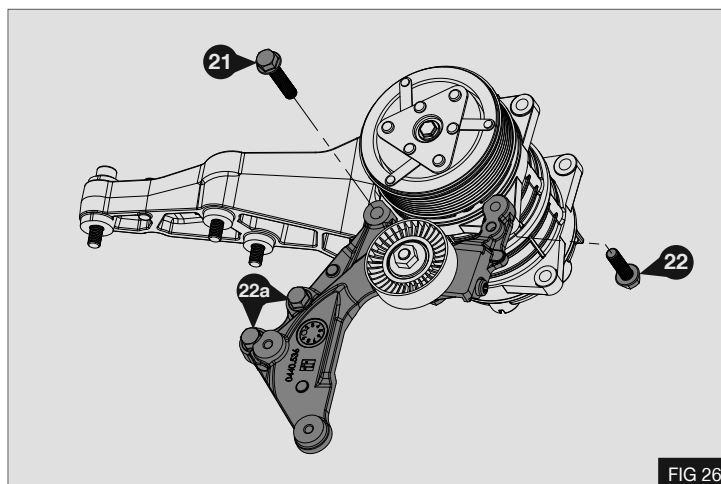

FIG 26

9. Refit the suction/discharge manifold (AH) and torque bolt (AG) to 25 Nm / 18 lb. ft. Slide the battery cable bracket (10) together with bolt (24) already installed into the cable holder and fasten it to the compressor as shown. - Fig 27

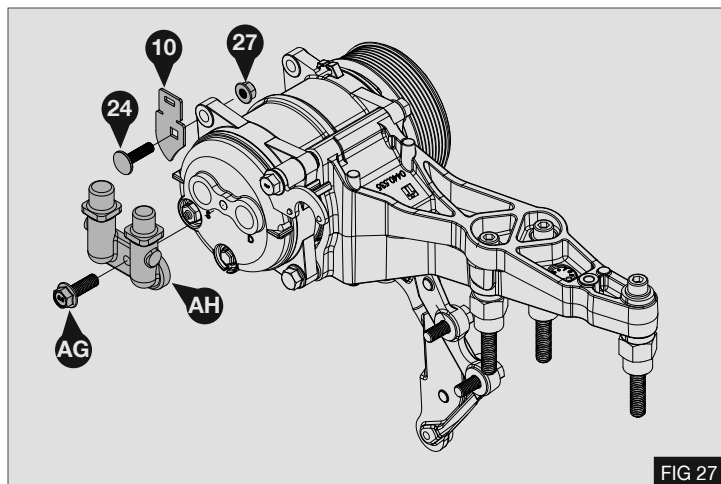

FIG 27

10. Torque bolts (19) to 58Nm / 43lb. ft. - Fig 27

11. Install idle pulleys (6) and (7) to bracket (2) using bolts (23) with spacers (14) as shown opposite. Torque bolts (23) to 29Nm / 22lb. ft. - Fig 28

**Note:** In order to install idle pulley (6) it may be necessary to temporarily move the engine over to the right slightly. To facilitate this insert a wedge between the engine mount and the mount bracket. You may also find it simpler to install the idle pulley from below.

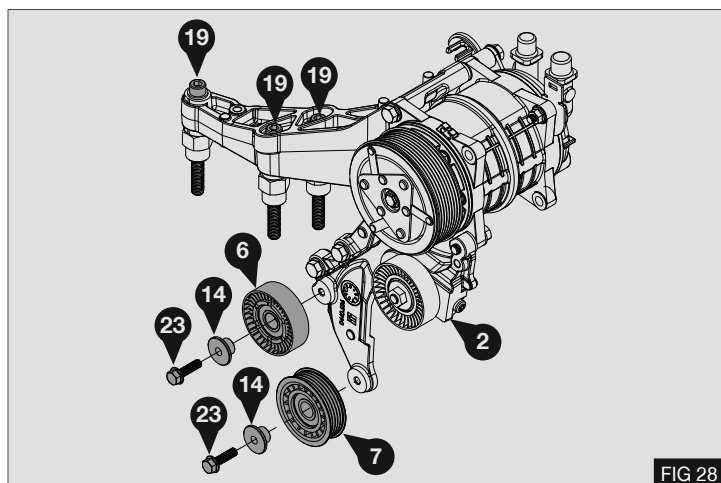
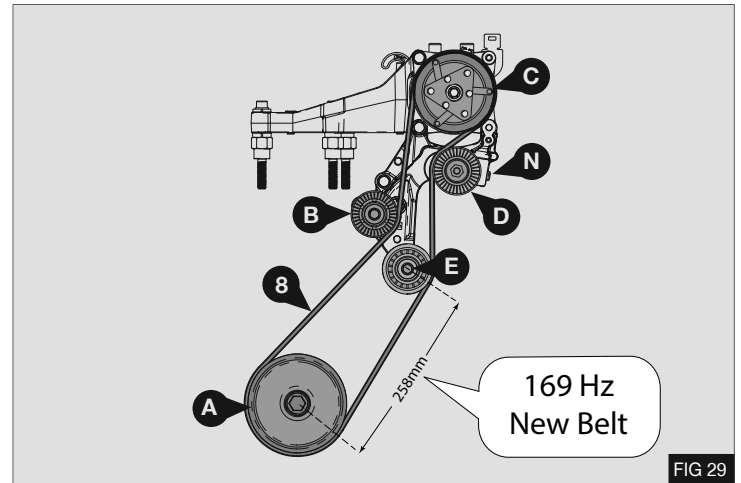

FIG 28

## DRIVE BELT

1. Install the supplied drive belt (8) as shown opposite - Fig 29

A – Crankshaft Pulley  
 B – Idle Pulley  
 C – Compressor  
 D – Adjuster Pulley  
 E – Grooved Idle pulley



2. Place the belt in the correct groove of the compressor – Fig 30
3. Tension the drive belt (8) using a T-40 Torx on the adjuster bolt (N). If the tension is being checked using a frequency meter, ensure that it is checked on the span shown - Fig 30

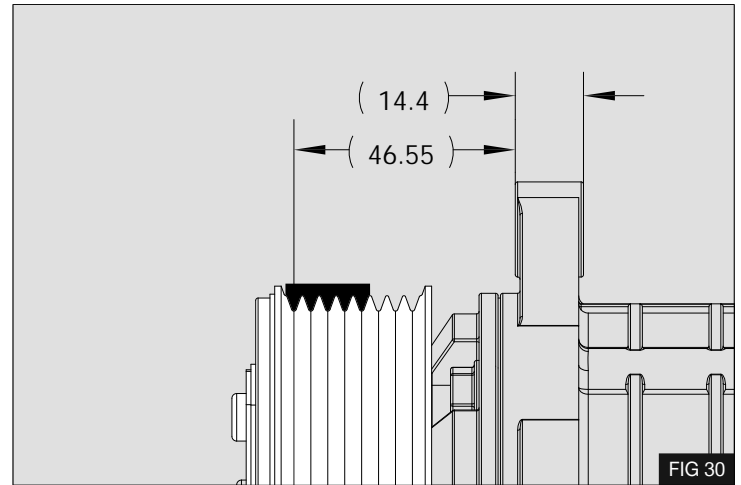

4. When the correct tension (new belt level) has been achieved (see table). Torque tensioner lock nut (P) to 25Nm / 18lb. ft. using a calibrated torque wrench - Fig 31

**Note:** A new drive belt must be tensioned to the “new belt level” in order to mesh correctly into the pulley grooves. The belt tension will then fall after a running in period.

BELT TENSION TABLE			
Belt	Belt Age	Belt Tension Using Belt Tension Gauge	Belt Tension (Hz)
5PK	New Belt	60 - 72 kg	169 Hz
5PK	Used/ re-tension Belt	45 - 50 kg	143 Hz

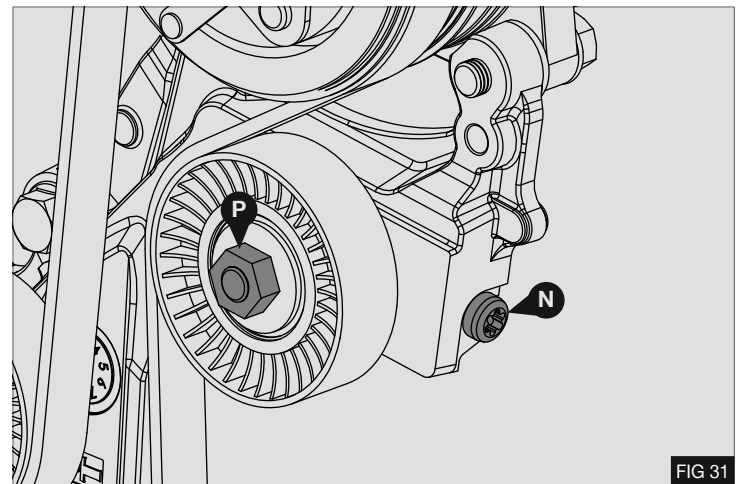

**ELECTRICAL INTERFACE**

1. Vehicles fitted with Stop / Start technology must have the fast idle activated when combined with this compressor mount kit.
2. Full details of how to complete this operation are contained within the Renault / Vauxhall / GM conversion guidelines for this vehicle in the following locations :-

**Renault** - 4.11 "CABADP" option / fast idle "RALENT" option

**Vauxhall** – 4.11 wiring loom for conversions option "KPD" / fast idle option "UF3"

3. The fast idle is activated by connecting pin 1 of the 6 way connector to earth – Fig 31
4. Location of the 6 way connector - The connector is located on the left-hand side of the dashboard, near to the panel feed-through ring, the passenger compartment fuse and relay box and the bonnet opening lever. It is secured on the dashboard wiring by a tie. Extra length is provided for the connection. The connector is in the same position for both left-hand and right-hand drive vehicles.
5. Manufacturers recommend that this connection is activated whenever the refrigeration / additional AC system is active
6. Manufacturers also provide a +12v battery power supply for use with auxiliary component wiring. This is a 2 way connector located behind the B-pillar trim.

**Note:** This power supply is connected directly to the battery (via fuse F6) and is therefore not protected by the energy management system. Therefore there is a risk of battery discharge.

**POST INSTALLATION**

1. Run the engine with compressor engaged for five minutes. Check all components.
2. Check the belt tension when the belt is hot. It is important that the belt is allowed to cool before re-tensioning. **Always re-tension new belts if the tension is less than the used belt amount.** Install the supplied belt label in the engine bay.

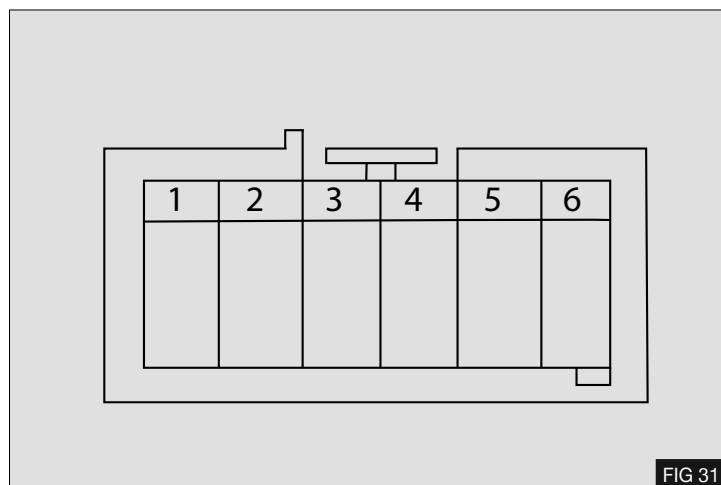

FIG 31

**6 Way connector**

Ways	Connections	Allocation	
1	3ADJ	Accelerated idle control (wire cross-section 0.5mm <sup>2</sup> )	
2	BMT1	'Engine running' Information	Shared 10A Fuse (wire cross-section 1mm <sup>2</sup> )
3	SBP4	+ 12V Load shedding current distribution power supply	
4	MAN32	Earth (wire cross-section 1.5mm <sup>2</sup> )	
5		Reserve	
6		Reserve	

**2 Way connector**

Ways	Connections	Allocation
1	BP23	+12V Direct battery power supply for maximum consumption of a 40A (wire cross-section 7mm <sup>2</sup> ) 50A fuse F6 protection
2	MAN32	Ground (wire cross-section 7mm <sup>2</sup> ) large enough to adapt to the battery +12V current



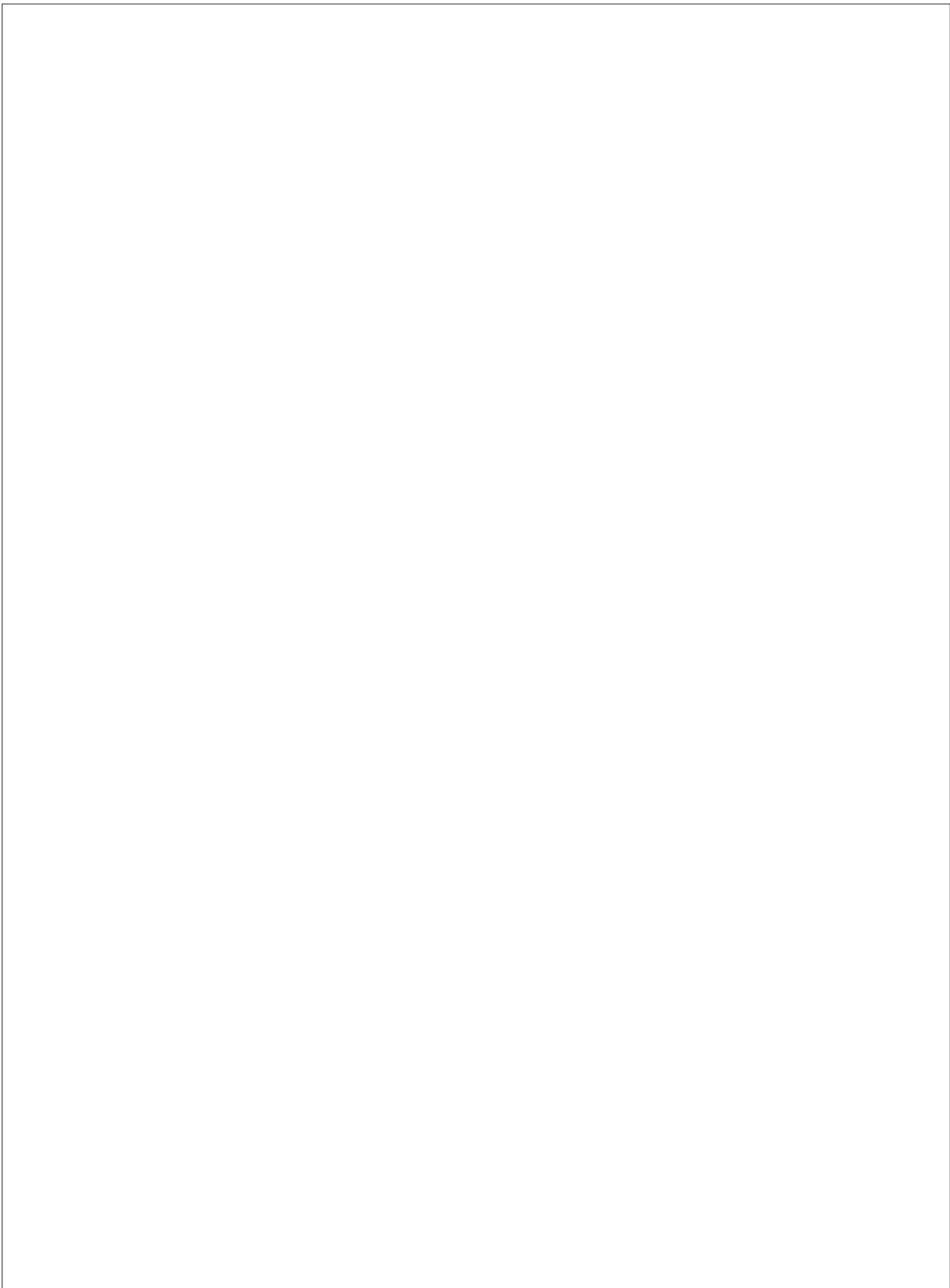

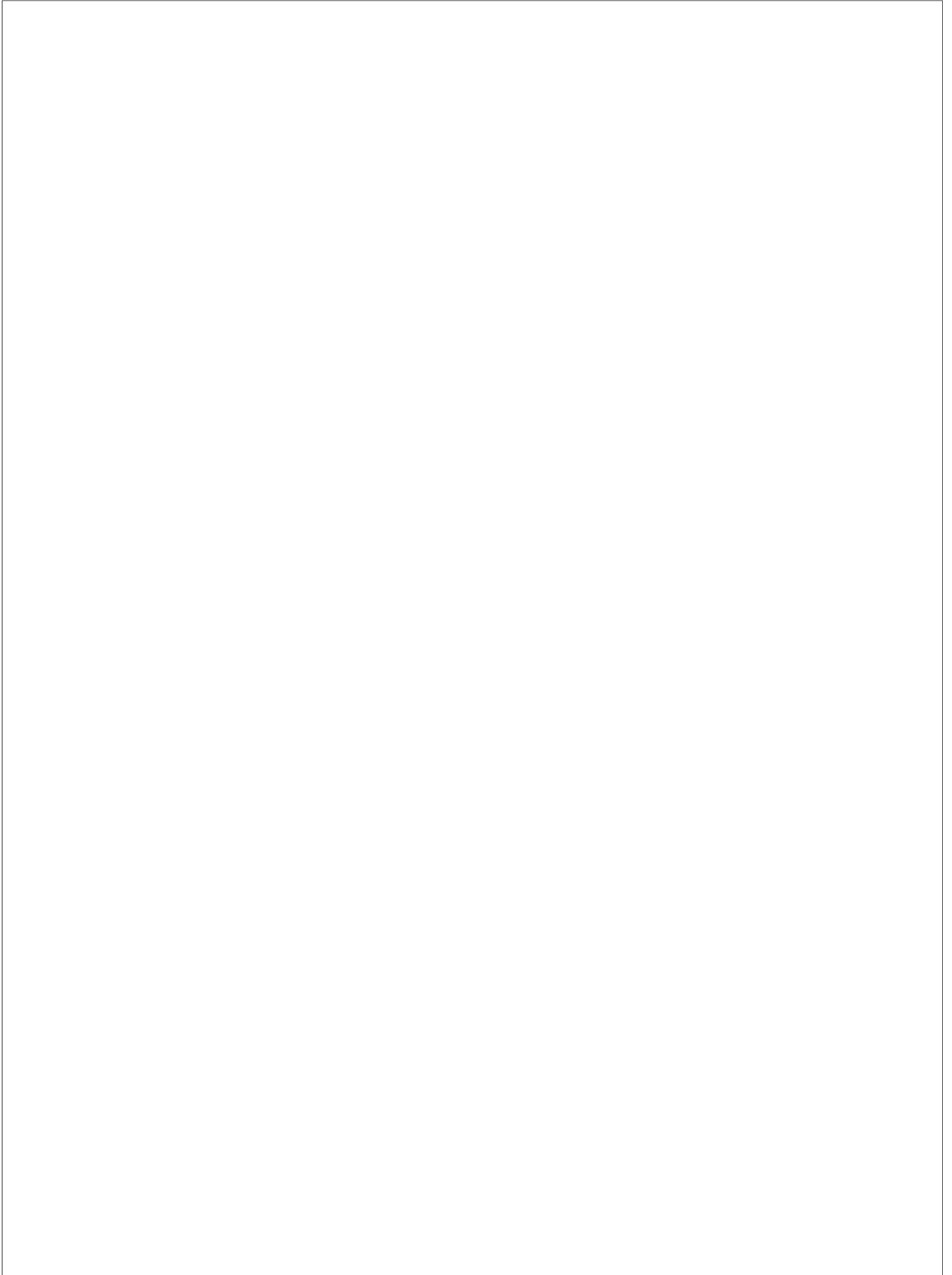

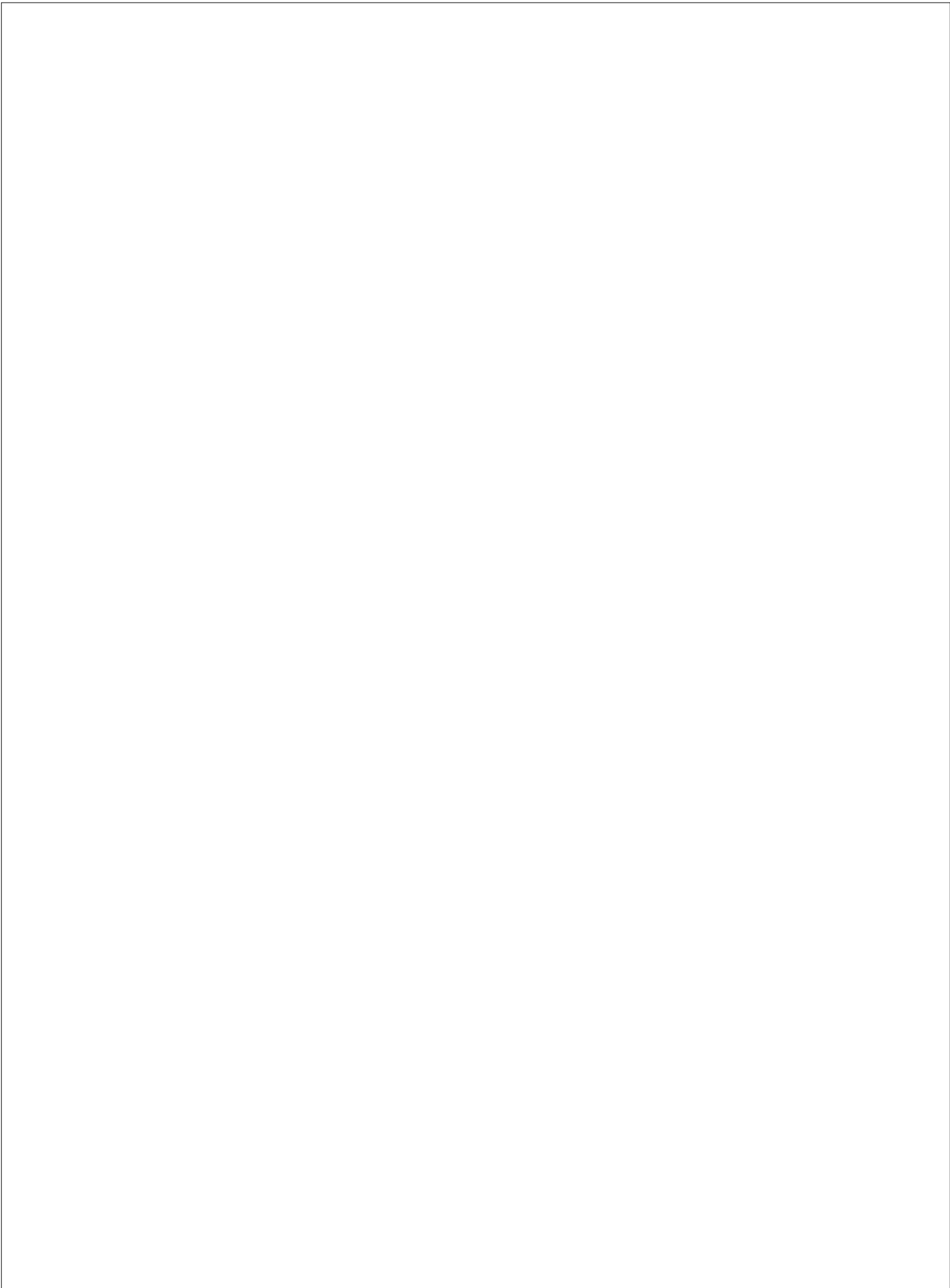

(EN)

Techni focuses on constant upgrading of its products. The Manufacturer reserves the right to modify the models and components described in the present publication at any time for technical or commercial reasons and without prior notice. For further information, contact Techni technical services.

(DE)

Techni ist stets bestrebt die eigenen Produkte zu verbessern. Die Herstellerfirma behält sich das Recht vor, aus technischen oder Verkaufsgründen, zu jeder Zeit und ohne vorherige Ankündigung, Abänderungen an den Modellen und den in dieser Veröffentlichung beschriebenen Einbauteile vorzunehmen. Für weitere Informationen bitten wir Sie, sich an unseren Techni Kundendienst zu wenden.

(FR)

Techni vise à une amélioration constante des ces produits. La maison se réserve le droit d'apporter, à tout moment et sans préavis, des modifications aux modèles et aux composants décrits dans cette publication pour des raisons d'ordre technique ou commerciale. Pour d'ultérieures informations s'adresser au service d'assistance Techni.

(IT)

Techni mira ad un costante miglioramento dei propri prodotti. La Casa si riserva il diritto di apportare in qualunque momento e senza preavviso modifiche ai modelli e ai componenti descritti in questa pubblicazione per ragioni di natura tecnica o commerciale. Per ulteriori informazioni rivolgersi al servizio assistenza Techni.

(ES)

Techni aspira a un constante mejoramiento de su producción. La Fábrica se reserva el derecho de aportar en cualquier momento y sin preaviso modificaciones a los modelos y los componentes descritos en esta publicación por razones técnicas o comerciales. Para ulteriores informaciones dirigirse al servicio asistencia Techni.

VENDITA E SERVIZIO  
VENTE ET SERVICE

SALES AND SERVICE  
VERKAUF UND SERVICE



Sundorne Trade Park, Henley Way,  
Shrewsbury, United Kingdom, SY1 4NS  
Telephone (+44) (0) 1743 443176  
Fax (+44) (0) 1743 443113  
Email: [sales@techni.co.uk](mailto:sales@techni.co.uk)